

## GENERAL INSTALLATION MANUAL FOR GAZIOGLU SOLAR ENERJİ PV MODULES

PLEASE READ THIS MANUAL CAREFULLY BEFORE INSTALLING OR USING THE MODULES.  
PLEASE PASS ALONG THE ATTACHED USER MANUAL TO YOUR CUSTOMER.

### 1. INTRODUCTION

- ☆ Thanks for choosing high quality modules from **Gazioglu Solar Enerji San ve Tic AŞ** (Hereinafter referred to as “**GAZIOGLU SOLAR ENERJİ**”)
- ☆ This Installation Manual contains essential information for the electrical and mechanical installation that you must know before installing **GAZIOGLU SOLAR ENERJİ** PV modules. This also contains safety information you need to be familiar with.
- ☆ All the information described in this manual are the intellectual property of and based on the technologies and experiences that have been acquired and accumulated in the history of **GAZIOGLU SOLAR ENERJİ**
- ☆ This document does not constitute a warranty, expressed or implied. **GAZIOGLU SOLAR ENERJİ** does not assume responsibility and expressly disclaims liability for loss, damage, or expense arising out of or in any way connected with installation, operation, use or maintenance of the PV modules. No responsibility is assumed by **GAZIOGLU SOLAR ENERJİ** for any infringement of patents or other rights of third parties that may result from use of PV module.
- ☆ **GAZIOGLU SOLAR ENERJİ** reserves the right to make changes to the product, specifications or installation manual without prior notice.

### 2. RULES AND REGULATIONS

- ☆ The mechanical and electrical installation of the module should obey local regulations, including electrical law, construction law and electricity connection requirements. These regulations are different in different installation site, such as the installation on the building roof, different installation environment of the power station. Requirements may also differ with the system voltage, the use of AC or DC. For the specific terms, please contact local authority.
- ☆ Before installing the PV module, contact appropriate authorities to determine permit, installation and inspection requirements that should be followed.
- ☆ Don't throw away the Modules Waste. Please contact local related departments or authorities.

### 3. GENERAL INFORMATION

#### 3.1 COMPONENTS OF Module

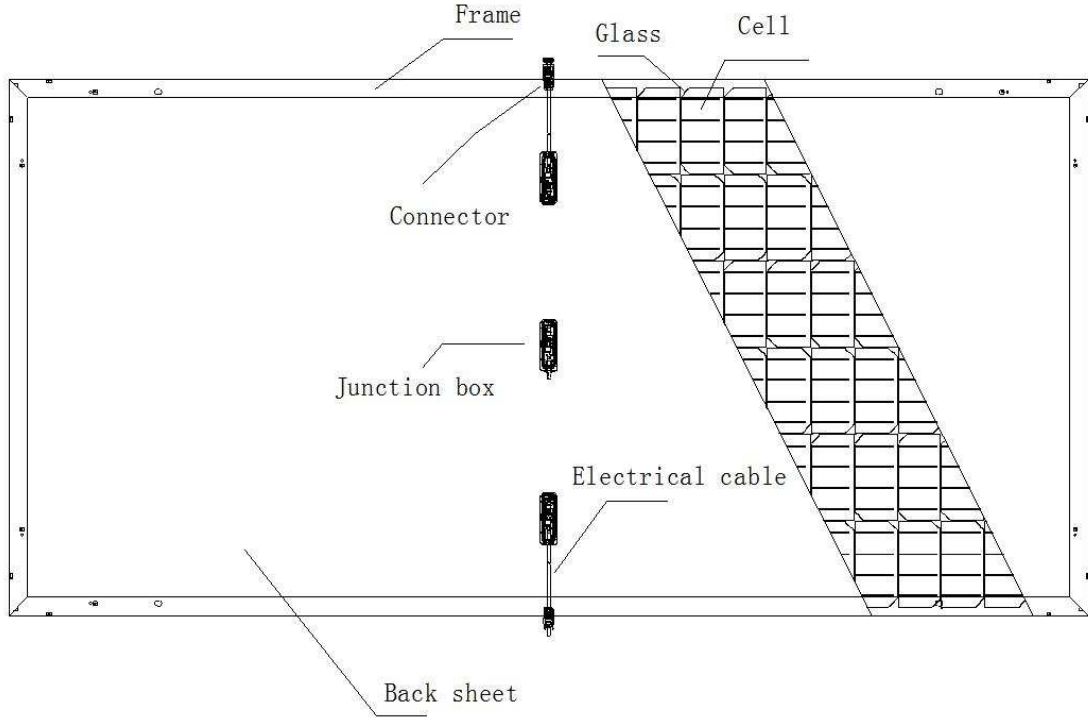

Figure 1. The components of a module

#### 3.2 GENERAL SAFETY

- ☆ **GAZIOGLU SOLAR ENERJİ** PV modules are designed in accordance with the international standard IEC61215, IEC61730. The solar modules have been qualified for application class A (equivalent to safety class II requirements).
- ☆ Installing PV modules and ground frames should be in accordance with applicable rules and regulations.
- ☆ Only installer/service personnel should have access to the PV module installation site. In order to avoid a risk of injury or electrical shock, do not allow anyone to approach the PV module if the person has little knowledge on PV module or on the measures that should be taken when PV modules are damaged.
- ☆ In the case that the PV modules are non-integral type, the module is to be mounted over a fire resistant roof.
- ☆ Follow all safety precautions of other components used in the system.
- ☆ Do not clean the glass surface with chemicals. Do not let water stay on the glass surface of PV modules for a long time. This creates a risk of white efflorescence (glass disease) which may result in the deterioration of energy generation.
- ☆ Do not install the PV module horizontally. It may cause dirt or white efflorescence (glass disease) due to water.
- ☆ Do not cover the water drain holes of the frame. There is a risk of frost damage when the frame is filled with water.

- ☆ When sliding snow load has to be considered, an appropriate measure has to be taken so that PV module frames on lower edge of PV modules will not be damaged.
- ☆ In case the glass surface of a PV module is broken, wear goggles and tape the glass to keep the broken pieces in place.
- ☆ The accessible PV module surface shall be smooth and free from sharp edges, burrs, etc.

### 3.3 ELECTRICAL SAFETY

- ☆ The installation of PV modules requires a great degree of skill and should only be performed by a qualified licensed professional, including licensed contractors and licensed electricians.
- ☆ Please read this manual carefully before installing or using the modules. Please be aware that there is a serious risk of various types of injury occurring during the installation including the risk of electric shock.
- ☆ All **GAZIOĞLU SOLAR ENERJİ** PV modules are equipped with a permanently attached junction terminal box that will accept variety of wiring applications or with a special cable assembly for ease of installation, and they do not require special assembly.
- ☆ Contact with electrically active parts of a PV module such as terminals can result in burns, sparks and lethal shock whether the PV modules is connected or not.
- ☆ PV modules produce electricity when the sunlight or other sources illuminate the module surface. When the modules are connected in series, voltage is cumulative. When the modules are connected in parallel, current is cumulative. As a result, a large-scale PV system can produce high voltage and current which could present an increased hazard and may cause serious injury or death.
- ☆ Do not connect the PV modules directly to the loads since the variation of the output power depending on the solar irradiation causes damage for the connected load.
- ☆ Turn off inverters and circuit breakers immediately, should a problem occur.
- ☆ A defective PV module may generate power even if it is removed from the system. It may be dangerous to handle the PV module while exposed to sunlight. Place a defective PV module in a carton after PV cells are completely shaded.
- ☆ Do not expose PV module to sunlight concentrated with mirrors, lenses or similar means.
- ☆ Do not shade portions of the PV module surface from the sunlight for a long time. The shaded cell may become hot (hot spot phenomenon) which results in solder joints peeling off.
- ☆ In case of series connection, the maximum open circuit voltage must not be greater than the specified maximum system voltage. The voltage is proportional to the number of series. In case of parallel connection, please be sure to take proper measure (e.g. fuse for protection of module and cable from over current, and/or blocking diode for prevention of unbalanced strings voltage) to block the reverse current flow. The current may easily flow in a reverse direction.

### 3.4 INSTALLATION SAFETY

- ☆ During transportation or storage, unless you reach the installation site, otherwise, do not open the package of the modules.
- ☆ Please protect the modules' package. When loading or unloading the modules, please handle with care. Do not drop the packed pallet of modules down directly.
- ☆ Before open the modules' package, store the modules in ventilated and dry place.
- ☆ When opening the modules' package with knife, be careful not scratching the module.
- ☆ Do not lift the whole module by grabbing the terminal box or cable in any sense.
- ☆ Modules are heavy. Handle with care. Do not drop PV modules far above ground. Do not drop one module down on another module.
- ☆ Do not stand or step on the module. Do not pass by stepping on the module especially when installing, maintain and washing the modules.
- ☆ Do not hit or put excessive load on the glass or back sheet. Do not allow objects fall down on the module.
- ☆ Do not cause an excessive load on the surface of PV module or twist the frame.
- ☆ Do not scratch or hit at the back sheet. Do not hit on the terminal box or do not pull the cables. Please notice the ground condition when the module is placed horizontally with back sheet faced down.
- ☆ Do not try to unpick the module, remove any parts or the nameplate of the module.
- ☆ Do not brush oil paint or any other adhesive on the surface of the module. Do not scratch the insulation coating of the frame (except for grounding connection). It may cause corrosion of the frame or compromise the framework strength.
- ☆ Do not drill holes in the frame. It may compromise the frame strength and cause corrosion of the frame.
- ☆ Do not repair glass, back sheet or other broken part of the module.
- ☆ Please install with dry tools in dry condition. Do not operate when the module is wet, unless wear proper equipment against electrical shock.
- ☆ Do not grab the PV module at only one side, the frame may bend. Grab the PV module at two sides facing each other.
- ☆ Do not touch the PV module with bare hands. The frame of PV module has sharp edges and may cause injury.
- ☆ Do not scratch the output cable or bend it with force. The insulation of output cable can break and may result in electricity leakage or shock.
- ☆ Do not try artificially to concentrate sunlight on the PV module. Neve touch terminal box or the end of output cables with bare hands when the PV module is irradiated. Cover the surface of PV module with cloth or other suitable sufficiently opaque material to isolate the PV module from incident light and handle the wires with rubber-gloved hands to avoid electric shock.
- ☆ Always wear protective head gear, insulating gloves and safety shoes (with rubber soles).

- ☆ Do not touch the PV module unnecessarily during installation. The glass surface and the frames get hot. There is a risk of burn, or you may collapse because of electric shock.
- ☆ Do not work under rain, snow or windy conditions.
- ☆ Do not touch the terminal box and the end of output cables the cable ends (connectors) with bare hands during installation or under sunlight, regardless of whether the PV module is connected to or disconnected from the system.
- ☆ Plug in the connector tight and ensure the wiring work. Do not unplug the connector if the system circuit is connected to a load.
- ☆ Do not stomp on the glass at work. There is a risk of injury or electric shock if glass is broken.
- ☆ Do not work alone (always work as a team of 2 or more people).
- ☆ When installing PV modules far above ground, wear a safety belt, do not drop any object (e.g., PV module or tools).
- ☆ Do not wear metallic jewellery which can cause electric shock during installation.
- ☆ Do not damage the back sheet of PV modules when fastening the PV modules to a support by bolts.
- ☆ Do not damage the surrounding PV modules or mounting structure when replacing a PV module.
- ☆ Bind cables by the insulation locks. Drooping down of cables from the terminal box could possibly cause various problems such as animal biting, electricity leakage in puddle.
- ☆ Take proper measures for preventing the laminate (consisted of resin, cells, glass, back sheet, etc.) from dropping out of the frame in case the glass is broken.
- ☆ Cables shall be located so that they will not be exposed to direct sunlight after installation to prevent degradation of cables.
- ☆ When installing the module, make sure that the terminal box is on the higher side of the module for better waterproof.

### 3.5 Fire SAFETY

- ☆ Consult your local authority for guidelines and requirements for building or structural fire safety. **GAZIOGLU SOLAR ENERJİ** modules have been listed as Class C according to IEC 61730-2 standard.
- ☆ For roof installations, modules should be mounted over a fire resistant covering suitable for this application, with adequate ventilation between the Modules backsheet and the mounting surface. In order to maintain the fire class rating, the distance between the Modules frame surface and the roof surface shall be at least 20 cm.
- ☆ Roof constructions and installations may affect the fire safety of building. Improper installation may create hazards in the event of a fire. Please install the Modules with Professional Installers.

## 4. INSTALLATION CONDITION

### 4.1 SITE SELECTION AND WORK ENVIRONMENT

- ☆ In most applications, the PV modules should be installed in a location where there is no shading throughout the year. Please make sure that there are no obstructions in the surroundings of the site of installation.
- ☆ **GAZIOGLU SOLAR ENERJİ** recommend that the PV modules should be installed in the place where the operating temperature is from  $-20^{\circ}\text{C}$  to  $46^{\circ}\text{C}$ . The operating temperature is the maximum and minimum monthly average temperature of the installation site. The limit of working temperature is from  $-40^{\circ}\text{C}$  to  $85^{\circ}\text{C}$ .
- ☆ **GAZIOGLU SOLAR ENERJİ** PV modules must be mounted on proper structure or any other place which is suitable for module installation (such as ground, roof and facade).
- ☆ Make sure flammable gases are not generated near the installation site.
- ☆ The PV modules should not be installed in flooded areas. The junction box should be on the higher side of the module when it is mounted.
- ☆ Lightning protection is recommended for PV systems that are to be installed in locations with high probability of lightning strikes.
- ☆ Take proper steps in order to maintain reliability and safety, in case the PV modules are used in areas such as: Heavy snow areas / Extremely cold areas / Strong wind areas / Installations over, or near, water / Areas where installations are prone to salt water damage / Small islands or desert areas.
- ☆ **GAZIOGLU SOLAR ENERJİ** suggests that modules should not be installed nor operated in areas where hail, snow, sand, dust, air pollution, soot, etc., are excessive. Modules must not be sited in locations where aggressive substances such as salt, salt mist, salt-water, chemically active vapours, acid rain, any other type of corrosive agent, could affect the safely the safely and/or performance of the Modules.
- ☆ If you are planning to use the PV modules where the salt water damage may be possible, please consult with **GAZIOGLU SOLAR ENERJİ** local agent first to determine an appropriate installation method, or to determine whether the installation is possible.
- ☆ **GAZIOGLU SOLAR ENERJİ** recommends that modules used or installed should be 2000 meters (altitude) at most.

### 4.2 TILT ANGLE

- ☆ The tilt angle of the PV module is the angle between the PV module and a horizontal ground surface. The PV module generates the maximum output power when it faces the sun directly.
- ☆ In the Northern Hemisphere, the PV modules should typically face south, and in the Southern Hemisphere, the PV modules should typically face north.
- ☆ For the detailed installation angle, which is different in different area, may refer to the recommendation of the experienced PV modules installation supplier.

- ☆ Modules mounted flat (0° tilt angle) is not suggested due to dust is easy to be accumulated and affect power output. Dust building up on the surface of the modules can impair with modules performance. **GAZIOĞLU SOLAR ENERJİ** recommends installing the modules with a tilt angle of at least 9 degrees, making it easier for dust to be washed off by rain and more regular cleaning is not required and water on the surface of module will not be accumulated, avoiding mouldy glass caused to affect the degradation of the modules because of long time water collection on the module surface.

## 5. ELECTRICAL INSTALLATION

### 5.1 WIRING AND CABLES

- ☆ To ensure proper system operation and to maintain your warranty, observe the correct cable connection polarity (Figures 2&3) when connecting the modules to a battery or to other modules. If not connected correctly, the bypass diode could be destroyed.
- ☆ PV modules can be wired in series to increase voltage. Connect wires from the positive terminal of one module to the negative terminal of the next module. Figure 2 shows modules connected in series
- ☆ Connect PV modules in parallel to increase current. Connect wires from the positive terminal of one module to the positive terminal on the next module. Figure 3 shows modules connected.

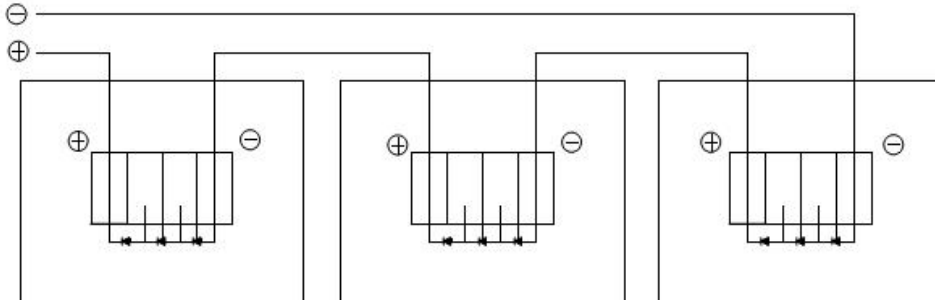

Figure 2.SERIES for more voltage

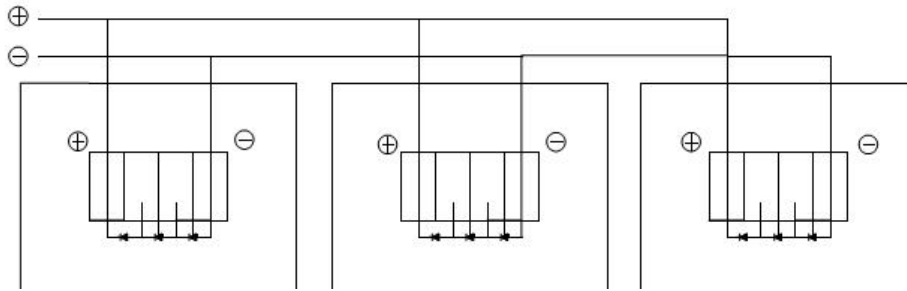

Figure 3.PARALLEL for more current

- ☆ These junction boxes have been designed to be easily interconnected in series for their well-connected cable and connector with IP67 protection grade at least.
- ☆ Each Modules has two single-conductor wires, one positive and one negative, which are pre-wired inside the junction box
- ☆ The connectors at the opposite end of these wires allow easy series connection of adjacent Modules by firmly inserting the positive connector of a Module into the negative connector of an adjacent Module until the connector is fully seated.

- ☆ Use field wiring with suitable cross-sectional areas that are approved for use at the maximum short-circuit current of the Modules. **GAZIOGLU SOLAR ENERJİ** recommends installers use only sunlight resistant cables qualified for direct current (DC) wiring in PV systems.
- ☆ Cables should be fixed to the mounting structure in such a way that mechanical damage of the cable and/or the modules is avoided. While the cables are sunlight resistant and waterproof, where possible, avoid direct sunlight exposure and water immersion of the cables.
- ☆ # Maximum parallel strings without proper measures (e.g. fuse and/or blocking diode): 1 string.  
Note: Parallel configuration is not limited in case of taking proper measure (e.g. fuse for protection of module and cable from overcurrent, and/or blocking diode for prevention of unbalanced strings voltage) to block the reverse current flow.
- ☆ The quantity of string connection for modules should be consulted by the professional institute. Parallel connection for only 2 pcs modules is not recommended.
- ☆ Rating required minimum field wiring:

Table1 Rating required minimum field wiring

Testing standard	Wire size	Temperature Rating
IEC 62930:2017	4mm <sup>2</sup>	-40°C to +90°C

## 5.2 CONNECTORS

- ☆ Keep connectors dry and clean, and ensure that connector caps are hand tight before connecting the Modules.
- ☆ Do not attempt to make an electrical connection with wet, soiled, or otherwise faulty connectors.
- ☆ Avoid sunlight exposure and water immersion of the connectors. Avoid allowing connectors to rest on the ground.
- ☆ Faulty connections can result in arcs and electrical shock. Check that all electrical connections are securely fastened. Make sure that all locking connectors are fully engaged and locked.
- ☆ The Suppliers and types of connectors should be in accordance with the Standard IEC 62852. For more details, please see the CDF.

## 5.3 BYPASS DIODES

- ☆ The junction boxes used with **GAZIOGLU SOLAR ENERJİ** modules contain bypass diodes wired in parallel with the PV cell strings. In the case of partial shading, the diodes bypass the current generated by the non-shaded cells, thereby limiting modules heating and performance losses. Bypass diode are not over-current protection device.
- ☆ The type and rating of bypass diode to be used must pass the tests (IEC 62790) of the Junction Box. For more details, please see the CDF related Junction Box.
- ☆ In the event of a known or suspected diode failure, installers or maintenance providers should contact **GAZIOGLU SOLAR ENERJİ**. Never attempt to open the junction box by yourself.



## 5.4 ELECTRICAL RATINGS

- ☆ Refer to the mechanical and electrical ratings of individual models of PV module in the annex of this manual.
- ☆ Under normal conditions, a photovoltaic module is likely to experience conditions that produce more current and/or voltage than reported at Standard Test Conditions. Accordingly, the values of Isc and Voc marked on this module should be multiplied by a factor of 1.25 when determining component voltage ratings, conductor capacities, fuse sizes and size of controls connected to the module output.

## 6. GROUNDING

- ☆ The frame grounding is considered within the requirement of local regulation at the site of installation.
- ☆ When needed this grounding, please refer to below example of connection. Please be careful in arranging the system ground so that the removal of one module from the circuit will not interrupt the grounding of any other modules. The modules should be grounded to the same electrical point.
- ☆ Each PV module has grounding holes. Do not drill additional grounding holes on the frame. And the negative pole of the module must be grounded. Otherwise, the module warranty may be void.
- ☆ An example of acceptable ground connection using a screw, nut (hardware not provided) and washer retaining a ground screw is shown in figure 4. The size of the grounding cable should be decided by the professional person who responsible for electrical installation. In a connection of this type, the hardware (such as a toothed locked washer / star washer) must score the frame surface to make positive electrical contact with the frame. The ground wire must be considered within the requirement of local and regulation at the site of installation.
- ☆ If steel parts used for grounding purpose, steel parts must be plated, painted or enamelled for protection against corrosion before usage.

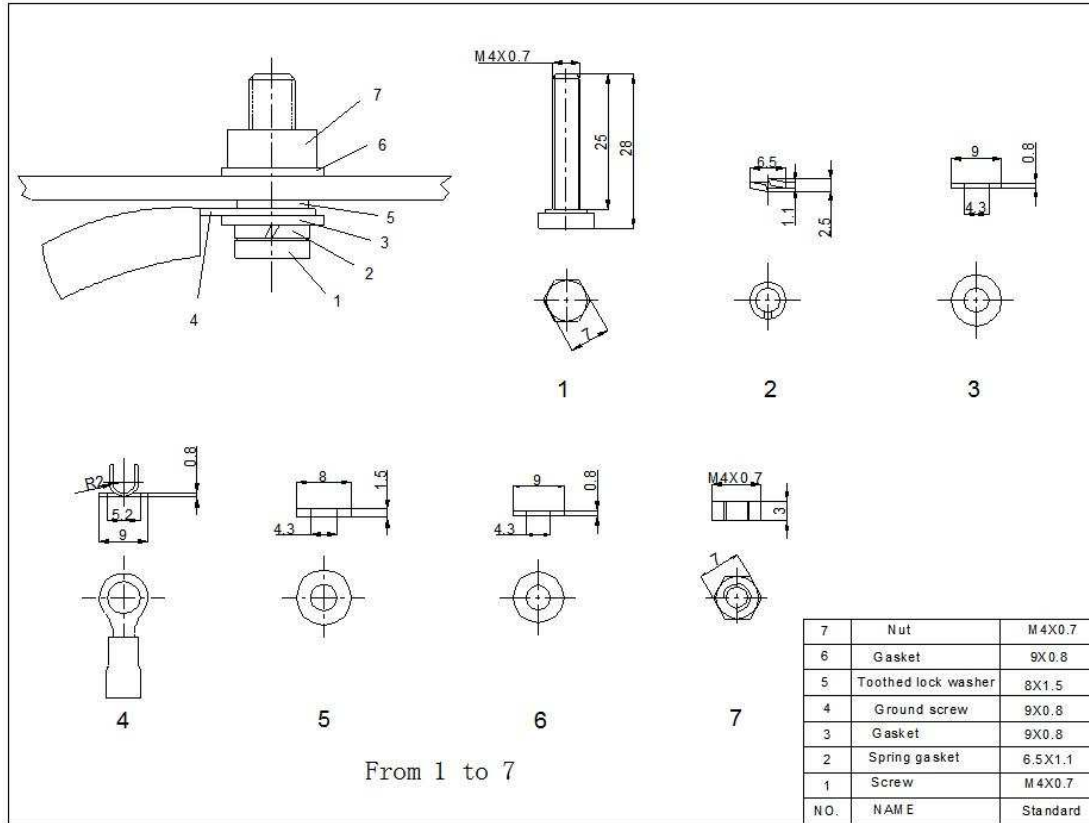

Figure 4.Example of acceptable ground connection

## 7. MECHANICAL GROUNDING

### 7.1 GENERAL REQUIREMENT

- ☆ Please make sure that all the information described in the installation manual is proper for your installation. Please review the descriptions and drawings carefully; not mounting the modules according to one of these methods may void your warranty.
- ☆ Support structures that PV modules are mounted on should be rigid. **GAZIOGLU SOLAR ENERJİ** PV modules are designed to secure their electric performance under the condition that they are mounted on rigid support structures. Deformation of support structure may damage PV module with its electric performance.
- ☆ If the modules are to be installed on the roof or wall of a building, the standoff method or the rack method is recommended. Clearance between the module frames and surface of the wall or roof is required to prevent the junction box from touching the mounting surface and to circulate cooling air around the back of the module. The exact space size may be decided by the installer or the system integrator based on the analysis of local weather and the specific roof structure involved.
- ☆ There are no limitations in the use of PV modules required to meet the building regulation requirements, in particular those relating to external fire spread. The PV modules can be used in concrete, slate or any other kinds of roofs which are strong enough and .the modules must be installed appropriately. Module installation will (must) ensure weatherproofing.

### 7.2 Installation Methods

- ☆ Please refer to below "Installation Methods".

## 8. MAINTENANCE

- ☆ The modules are designed for long life. The regular inspection and maintenance of the module must be carried out especially during the warranty period. It is the responsibility user must bear. When the module gets damaged, inform the supplier in time (usually 2 weeks).
- ☆ If the angle of the PV module is 9 degrees or more, normal rainfall is sufficient to keep the module glass surface clean under most weather conditions. If dirt build-up becomes excessive, clean the glass surface only with a soft cloth using water. If cleaning the back of the module is required, take utmost care not to damage the back side materials. Do not use acidic or alkaline cleaning agent to wash the modules. In order to ensure modules' maximum power output, please clean the modules frequency.
- ☆ Do not trample on the module when wash it. Do the security work.
- ☆ In order to ensure the operation of the system, please check the connection of wiring and the state of the jacket of wires every now and then.
- ☆ If modules (Slanting Installation) are covered with thick snow, especially, at the bottom of the module surface, you shall take proper measures to remove the snow.

## 9. OTHER

- ☆ Meaning of crossed –out wheeled dustbin:



Do not dispose of electrical appliances as unsorted municipal waste, use separate collection facilities. Contact your local government for information regarding the collection systems available. If electrical appliances are disposed of in landfills or dumps, hazardous substances can leak into the groundwater and get into the food chain, damaging your health and well-being. When replacing old appliances with new ones, the retailer is legally obligated to take back your old appliance for disposals at least free of charge.

## Installation Methods

### Mounting Using Clips on Long Edge of Module:

#### 1) Long Edge Parallel to Array Rails (Figure 5)

The modules can be mounted using clips (clamps) designed for solar modules as shown in 5.

The modules may be mounted using clips (clamps) on the long sides of the module when the array rails are parallel to the long sides, as shown in Figures 6. Note that the clip positions are important: the clip centrelines must be according to Figure 8. The module must be supported along the length of the long edge, and should overlap the array rail by at least 20mm. Note that the mounting clips should meet the minimum dimensions (catch width of 5mm and length of 30mm) as shown in Figure 5.

The array rails must support the bottom of the modules and must be continuous pieces (no breaks in the rail).

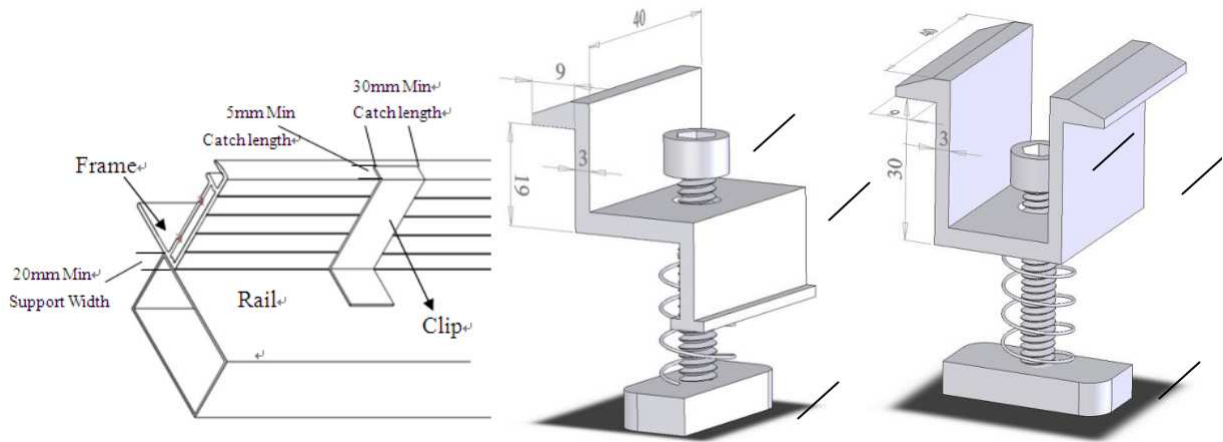

6	Nut	M8	S35C
5	Clip2	As shown in figure c)	Material
4	Screw	M8	S35C
3	Nut	M8	S35C
2	Clip1	As shown in figure b)	Material
1	Screw	M8	S35C
NO.	NAME	Standard	Material

Figures 5.

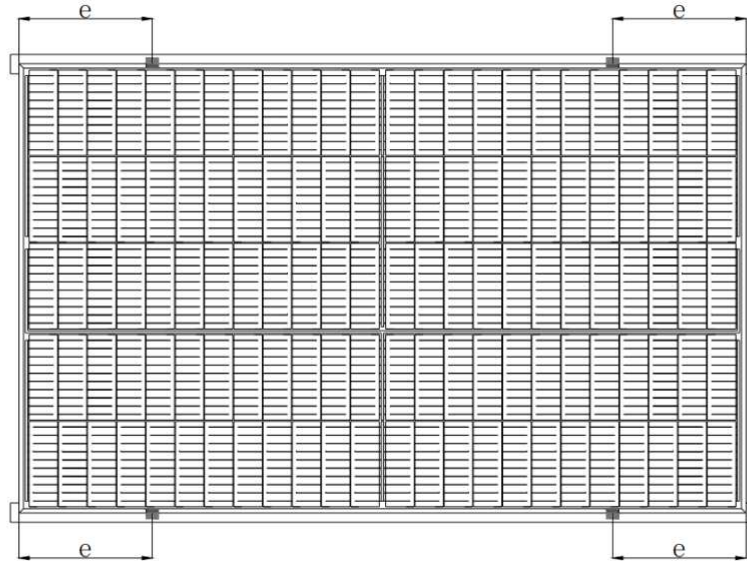
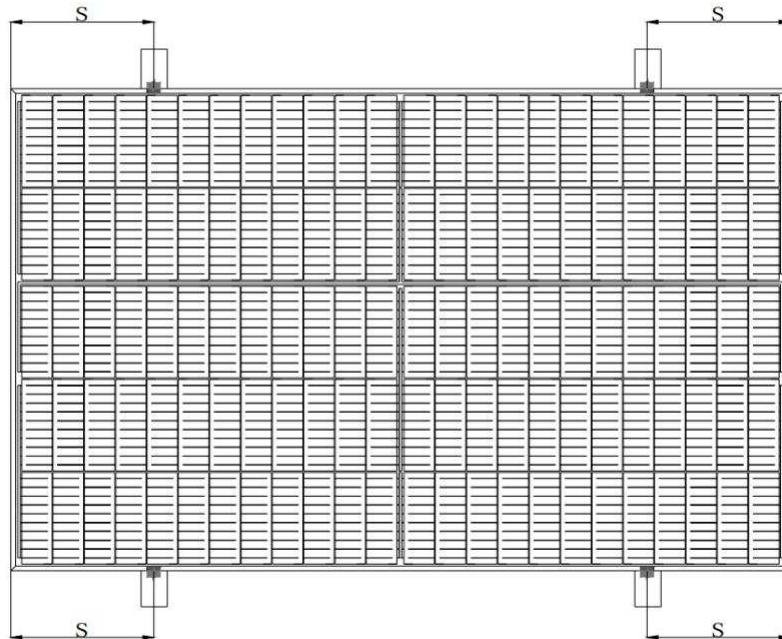

Figure 6. e is acc. to Fig.8

## 2) Long Edge Perpendicular to Array Rails (Figure 7)

The modules may also be mounted using clips (clamps) on the long sides of the module when the array rails are perpendicular to the long sides, as shown in Figure 7. The clip centrelines must be according to Fig.8. Note that the mounting clips should meet the minimum dimensions (catch width of 5mm and length of 30mm) shown in Figure 5. The array rails must support the bottom of the modules and must be continuous pieces (no breaks in the rail)



Figures 7. S is acc. to Fig.8

- ☆ The installation methods of PV module are accordance with the above diagram.
- ☆ The designed for front side to allow module loading and back side to allow module loading are different depend on model type (a safety factor is 1.5), please see below table of for detail.

Type Name of module	PV module size L×W×H(mm)	Distance for installation(mm)	Design Load (Pa) (Front side/Back side)
GSE-HCxxxMP	2095×1039×35	300mm<e<350mm 450mm<s<500mm	+3600/-2400
GSE-HCxxx	1756×1039×35	270mm<e<320mm 420mm<s<470mm	+3600/-2400
GSEGxxx-120M	2178×1303×35	350mm<e<400mm 450mm<s<500mm	+5400/-2400
GSEGxxx-108M	1965×1303×35	290mm<e<340mm 440mm<s<490mm	+5400/-2400
GSEGxxx-96M	1754×1303×35	270mm<e<320mm 420mm<s<470mm	+5400/-2400
GSExxx-144M	2279×1134×35	350mm<e<400mm 450mm<s<500mm	+5400/-2400
GSExxx-132M	2094×1134×35	300mm<e<350mm 450mm<s<500mm	+5400/-2400
GSExxx-120M	1909×1134×35	290mm<e<340mm 440mm<s<490mm	+5400/-2400
GSExxx-108M	1724×1134×35	270mm<e<320mm 420mm<s<470mm	+5400/-2400

Figure 8.

## ANNEX: MECHANICAL AND ELECTRICAL RATINGS

Standard Test Conditions is 1000 W/m<sup>2</sup>, T<sub>c</sub> 25°C, AM 1.5.

P<sub>max</sub> of any individual module will be within ±3% tolerance of these specified values.

V<sub>oc</sub> of any individual module will be within ±3% tolerance of these specified values.

I<sub>sc</sub> of any individual module will be within ±3% tolerance of these specified values.

Specifications and electric characteristics in Table 1 are subject to technical and product innovations.

Information in this document is subject to change without notice.

**Table 1: Specifications for GAZIOĞLU SOLAR ENERJİ –series photovoltaic modules under STC**

Type Name of module	Maximum Power (P <sub>max</sub> ) [W]	Open Circuit Voltage (V <sub>oc</sub> ) [V]	Voltage at Maximum Power (V <sub>mp</sub> ) [V]	Short Circuit Current (I <sub>sc</sub> ) [A]	Current at Maximum Power (I <sub>mp</sub> ) [A]	Fuse Rating [A]	Maximum System Voltage (V <sub>sys</sub> ) [V]
GSEGxxx-120M (xxx=580-610, in steps of 5, 120 cells)	610	41.60	34.80	18.40	17.53	25	1500
	605	41.52	34.60	18.34	17.49	25	1500
	600	41.40	34.40	18.24	17.44	25	1500
	595	41.32	34.20	18.11	17.40	25	1500
	590	41.21	34.00	18.02	17.35	25	1500
	585	41.15	33.80	17.91	17.31	25	1500
	580	41.10	33.60	17.81	17.27	25	1500
GSEGxxx-108M (xxx=525-545, in steps of 5, 108 cells)	545	37.30	31.20	18.30	17.47	25	1500
	540	37.10	31.00	18.22	17.42	25	1500
	535	36.90	30.80	18.10	17.38	25	1500
	530	36.70	30.60	18.00	17.33	25	1500
	525	36.50	30.40	17.89	17.28	25	1500
GSEGxxx-96M (xxx=470-485, in steps of 5, 96 cells)	485	32.90	27.90	18.31	17.40	25	1500
	480	32.70	27.70	18.23	17.34	25	1500
	475	32.50	27.50	18.10	17.29	25	1500
	470	32.30	27.30	18.02	17.23	25	1500
GSExxx-144M (xxx=520-560, in steps of 5, 144 cells)	560	50.13	41.63	14.05	13.45	20	1500
	555	49.98	41.48	13.97	13.37	20	1500
	550	49.83	41.33	13.91	13.30	20	1500
	545	49.68	41.18	13.85	13.24	20	1500
	540	49.53	41.03	13.80	13.17	20	1500
	535	49.38	40.88	13.75	13.08	20	1500
	530	49.23	40.73	13.70	13.02	20	1500
	525	49.08	40.58	13.65	12.93	20	1500
GSExxx-132M (xxx=480-510, in steps of 5, 132 cells)	510	45.67	38.42	13.80	13.28	20	1500
	505	45.54	38.27	13.69	13.20	20	1500
	500	45.41	38.11	13.58	13.12	20	1500
	495	45.28	37.95	13.47	13.04	20	1500
	490	45.13	37.89	13.36	12.93	20	1500
	485	45.02	37.77	13.25	12.84	20	1500
	480	44.91	37.65	13.16	12.75	20	1500
GSExxx-120M (xxx=435-465, in steps of 5, 120 cells)	465	41.46	34.72	13.96	13.40	20	1500
	460	41.39	34.57	13.85	13.31	20	1500
	455	41.32	34.42	13.75	13.22	20	1500
	450	41.25	34.21	13.62	13.16	20	1500
	445	41.10	34.06	13.52	13.07	20	1500
	440	40.95	33.94	13.41	12.95	20	1500
	435	40.82	33.85	13.31	12.85	20	1500
GSExxx-108M (xxx=390-420, in steps of 5, 108 cells)	420	37.24	31.13	13.80	13.49	20	1500
	415	37.20	31.07	13.74	13.35	20	1500
	410	37.16	31.01	13.67	13.22	20	1500
	405	37.12	30.98	13.60	13.07	20	1500
	400	37.08	30.92	13.53	12.94	20	1500
	395	37.04	30.86	13.47	12.80	20	1500

	390	37.00	30.80	13.41	12.66	20	1500
GSE-HCxxxMP (xxx=430-470, in steps of 5, 144 cells)	470	50.10	41.60	11.86	11.29	20	1500
	465	49.90	41.35	11.79	11.24	20	1500
	460	49.70	41.10	11.73	11.19	20	1500
	455	49.50	40.90	11.66	11.12	20	1500
	450	49.30	40.70	11.60	11.05	20	1500
	445	49.10	40.50	11.53	10.98	20	1500
	440	48.90	40.30	11.46	10.92	20	1500
	435	48.70	40.10	11.39	10.86	20	1500
	430	48.50	39.90	11.31	10.78	20	1500
GSE-HCxxx (xxx=360-390, in steps of 5, 120 cells)	390	42.50	34.50	11.64	11.29	20	1500
	385	42.20	34.25	11.58	11.24	20	1500
	380	41.90	34.00	11.52	11.19	20	1500
	375	41.60	33.75	11.45	11.12	20	1500
	370	41.30	33.50	11.37	11.05	20	1500
	365	41.00	33.25	11.30	10.98	20	1500
	360	40.70	33.00	11.24	10.92	20	1500